

# PMB's TP-100

## CIGAR TIPPING MACHINE



The PMB TP-100 is one of the machines in the PMB 100 system. It can either be an independent unit or be synchronously coupled to a film-wrapping machine (C-100), an ordinary or a rollband banding machine (S-100/R-100) and/or a cedar wood wrapping machine (W-100). Its speed is continuously adjustable up to an output of 120 cigars (or similar products) per minute.

The PMB TP-100 is used for tipping, the first step in the finishing of cigars. The TP-100 handles practically all common models of cigars and tips. To change the model of cigars or tips, adjustments to the machine are usually sufficient.

Distinctive for the PMB TP-100 are simplicity of design and dependability of operation. The tip hopper holds sufficient tips for about 1 hour's running. A vibrator conveyor is provided for feeding the tips to the fitting station, where glue is applied to the inner circumference of the tip before attachment to the cigar.

The cigars will have to be put down by hand or brought forward from a special feeder (e.g. type JL-100) onto the feedbelt of the machine. From there the product is moved individually to the fitting station, travelling sideways so that the wrapper is not damaged. Prior to and during tipping the cigar is held firmly while the relative location of the tip is adjusted before assembling. The glue application ensures a tight bond between cigar and tip, with no risk of exuding glue or "side leaks".

**Specialists in machinery and equipment for the cigar industry**



**CREATIVE SUPPORT FOR YOUR BUSINESS**

## TECHNICAL DATA PMB'S TP-100

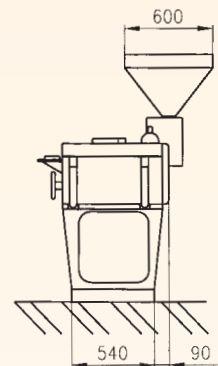
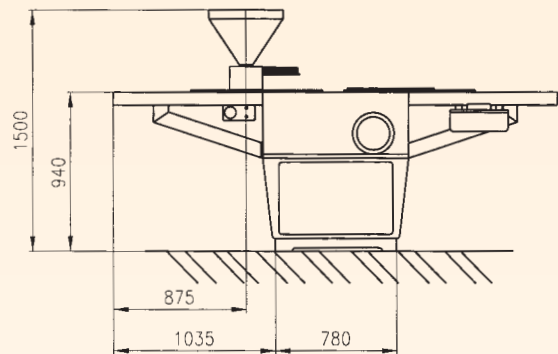
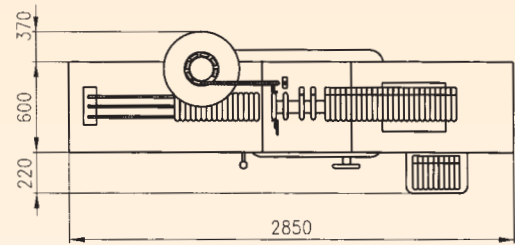

### PMB's C-100

|                           |                                 |
|---------------------------|---------------------------------|
| Capacity:                 | up to approx. 110 cigars/minute |
| Cigar diam.:              | 8-20 mm                         |
| Cigar length:             | 80-160 mm                       |
| Tip length:               | 25-50 mm                        |
| Motor:                    | 1,1 kW                          |
| Length:                   | 2850 mm                         |
| Width:                    | 1190 mm                         |
| Height:                   | 1500 mm                         |
| Weight, net:              | 575 kg                          |
| Weight, gross:            | 875 kg                          |
| Shipping cubic:           | 4.7 m <sup>3</sup>              |
| Length TP/C-100, TP/S-100 | 3750 mm                         |
| Length TP/RSC-100         | 4650 mmg                        |

**The PMB policy is one of continuous development and, therefore, we reserve the right to alter the above specification without notice.**

### Head office:

|                                  |                          |
|----------------------------------|--------------------------|
| PMB-UVA International B.V.       | Meerenakkerweg 32        |
| P.O. Box 7196, 5605 JD Eindhoven | 5652 AV Eindhoven        |
| The Netherlands                  | The Netherlands          |
| Telephone +31 (0)40 2825000      | uvapackaging@pmb-uva.com |
| Telefax +31 (0)40 2825001        | www.pmb-uva.com          |

### Sales and Service for USA and Canada:

|                           |                             |
|---------------------------|-----------------------------|
| PMB-UVA, Inc.             | 8111 Virginia Pine Ct.      |
| P.O. Box 34410            | Richmond, Virginia 23237    |
| Richmond, Virginia 23234  | United States of America    |
| United States of America  | uvapackaging@pmb-uvainc.com |
| Telephone +1 804 275 8067 | www.pmb-uvainc.com          |
| Telefax +1 804 271 3096   |                             |



CREATIVE SUPPORT FOR YOUR BUSINESS



MEMBER OF VDL GROEP B.V.